

High Expansion Fixed Generator

● PHYSICAL DATA

• Structure	Stainless Steel	
• Ring	Carbon Steel	
• Nozzles	Brass	
• Finish	polyurethane enamel RAL3000	
• Dimensions	1905 x 936 x 936 mm	
• Working pressure	3 – 7 Bar (50 – 100 psi)	
• MODELS	R70	R11
• Factor K	122	188
• Flow rate @ 5 Bar – 75 Psi en GPM	70	110
• Foam volume m ³ /min	180	260
• Weight Kg	57,5	58,5

● PERFORMANCE & WARRANTY

GHX-R is a high expansion foam generator for fixed systems, easy to install. GHX-R works with water pressure. It starts to work when the foam solution gets into the nozzles.

The generators are fixed in the top area of the warehouse. They can be installed horizontally on the Wall or vertically under the roof. They must be placed in a symmetrical pattern so they can fill up the warehouse in an even way.

They can achieve an expansion from 600 to 1000, depending on foam quality and on pressure.

They are connected to the water network with various 2 1/2" coupling type or flanges, according to your specification.

We advise to gat 5 bars – 75 Psi – at the generator inlet to get the best foam expansion.

GHX-R has a 1 year warranty.

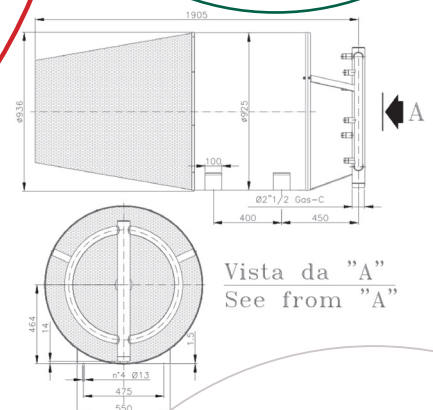
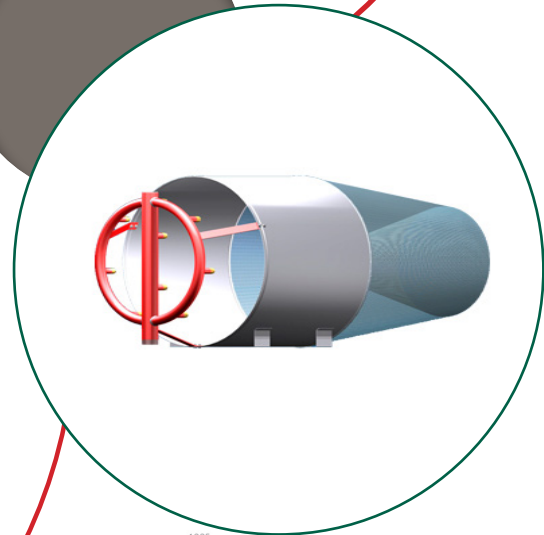

Vista da "A"
See from "A"



Tel. +44 (0) 1536 202919 • Fax +44 (0) 1536 263641 • sales@3fff.co.uk

Unit B, 18 Brunel Road, Earlstree Industrial Estate,
Corby, Northants, NN17 4JW, United Kingdom

V.A.T. Registration No: 938 9418 70 • Registered in England: 06236589